

- Four foot (1.3 m) multiband, eight port antenna with a 45° azimuth beamwidth covering 698-798, 824-896 MHz and 1695-2360 MHz frequencies
- Four wide high band ports covering 1695-2360 MHz and four frequency specific low band ports covering 698-798 MHz and 824-896 MHz (over a distributed diplexer) in a single antenna
- Full Spectrum Compliance for WCS and AWS-3 frequencies and upcoming Band 14 Operations
- LTE Optimized FBR and SPR performance, providing for an efficient use of valuable radio capacity
- LTE Optimized Boresight and Sector XPD and USL performance, essential for LTE Performance
- Exceeds minimum PIM performance requirements
- Equipped with new 4.3-10 connector, which is 40% smaller than traditional 7/16 DIN connector
- Equipped with 3 field replaceable, integrated AISG 2.0 compliant Remote Electrical Tilt (RET) Controllers (Type 1 External)

## Overview

The CCI OctoPort multiband array is an eight port antenna, with four wide high band ports covering 1695-2360 MHz and four frequency specific low band ports covering 698-798 MHz and 824-896 MHz. The antenna provides the capability to deploy 4x4 Multiple-input Multiple-output (MIMO) in the high band and 2x2 Multiple-input Multiple-output across each of the paired low band ports.

The CCI OctoPort allows independent tilt control between the low band ports and high band ports, in a three RET Controller (Type 1 External) configuration. The 1st RET is dedicated for the 700 MHz Low Band ports and the 2nd RET is dedicated for the 850 MHz Low Band ports. The 3rd RET is dedicated for the High Band ports. With the use of a single RET in the High Band, equal tilt is achieved across all four High Band ports, which ensures optimal 4x4 MIMO performance.

CCI antennas are designed and produced to ISO 9001 certification standards for reliability and quality in our state-of-the-art manufacturing facilities.

## Applications

- 4x4 MIMO for the high band and 2x2 MIMO for each the low band ports
- Ready for Network Standardization on 4.3-10 DIN connectors
- With CCI's multiband antennas, wireless providers can connect multiple platforms to a single antenna, reducing tower load, lease expense, deployment time and installation costs



OctoPort Multi-Band Antenna

OPA45R-BU4A

SPECIFICATIONS

Electrical

Ports	2 × Low Band Ports for 698-798 MHz	2 × Low Band Ports for 824-896 MHz
Gain <sup>1</sup>	14.5 dBi	14.8 dBi
Gain (Average) <sup>2</sup>	14.0 dBi	14.1 dBi
Azimuth Beamwidth (-3dB)	51°	45°
Elevation Beamwidth (-3dB)	17.8°	15.1°
Electrical Downtilt	0° to 14°	0° to 14°
Elevation Sidelobes (1st Upper)	<-17 dB	<-16 dB
Front-to-Back Ratio @180°	> 35 dB	> 35 dB
Cross-Polar Discrimination at Peak	> 25 dB	> 25 dB
Cross-Polar Discrimination over 10 dB <sup>2</sup>	14.8 dB	10.6 dB
Cross-Polar Port-to-Port Isolation	> 25 dB	> 25 dB
Voltage Standing Wave Ratio (VSWR)	< 1.5:1	< 1.5:1
Passive Intermodulation (2x20W)	≤ -150 dBc	≤ -150 dBc
Input Power Continuous Wave (CW)	500 watts	500 watts
Polarization	Dual Linear 45°	Dual Linear 45°
Input Impedance	50 ohms	50 ohms
Lightning Protection	DC Ground	DC Ground

<sup>1</sup>Peak gain across sub-bands.

<sup>2</sup>Electrical specifications follow document "Recommendation on Base Station Antenna Standards" (BASTA) V9.6.

Ports	4 × High Band Ports for 1695-2360 MHz			
Frequency Range	1695-1880 MHz	1850-1990 MHz	1920-2180 MHz	2305-2360 MHz
Gain <sup>1</sup>	17.3 dBi	17.5 dBi	17.6 dBi	17.8 dBi
Gain (Average) <sup>2</sup>	16.4 dBi	17.0 dBi	17.1 dBi	17.0 dBi
Azimuth Beamwidth (-3dB)	50°	48°	48°	40°
Elevation Beamwidth (-3dB)	10.2°	9.4°	9.0°	8.3°
Electrical Downtilt	0° to 10°	0° to 10°	0° to 10°	0° to 10°
Elevation Sidelobes (1st Upper)	<-17 dB	<-17 dB	<-17 dB	<-17 dB
Front-to-Back Ratio @180°	> 35 dB	> 35 dB	> 35 dB	> 35 dB
Cross-Polar Discrimination at Peak	> 24 dB	> 25 dB	> 25 dB	> 25 dB
Cross-Polar Discrimination over 10 dB <sup>2</sup>	11.0 dB	10.2 dB	9.9 dB	11.1 dB
Cross-Polar Port-to-Port Isolation	> 25 dB	> 25 dB	> 25 dB	> 25 dB
Voltage Standing Wave Ratio (VSWR)	< 1.5:1	< 1.5:1	< 1.5:1	< 1.5:1
Passive Intermodulation (2x20W)	≤ -150 dBc	≤ -150 dBc	≤ -150 dBc	≤ -150 dBc
Input Power Continuous Wave (CW)	300 watts	300 watts	300 watts	300 watts
Polarization	Dual Linear 45°	Dual Linear 45°	Dual Linear 45°	Dual Linear 45°
Input Impedance	50 ohms	50 ohms	50 ohms	50 ohms
Lightning Protection	DC Ground	DC Ground	DC Ground	DC Ground

<sup>1</sup>Peak gain across sub-bands.

<sup>2</sup>Electrical specifications follow document "Recommendation on Base Station Antenna Standards" (BASTA) V9.6.



OctoPort Multi-Band Antenna

OPA45R-BU4A

SPECIFICATIONS

Mechanical

Dimensions (LxWxD)	50.2x18.6x8.2 in (1275x472x210 mm)
Survival Wind Speed	> 150 mph (> 241 kph)
Front Wind Load	200 lbs (891 N) @ 100 mph (161 kph)
Side Wind Load	100 lbs (445 N) @ 100 mph (161 kph)
Equivalent Flat Plate Area	7.8 ft <sup>2</sup> (0.7 m <sup>2</sup> )
Weight *	49.4 lbs (22.4 kg)
RET Weight	5.0 lbs (2.3 kg)
Connector	8 x 4.3-10 female
Mounting Pole	2 to 5 in (5 to 12 cm)

\* Weight excludes mounting and RET

Bottom View

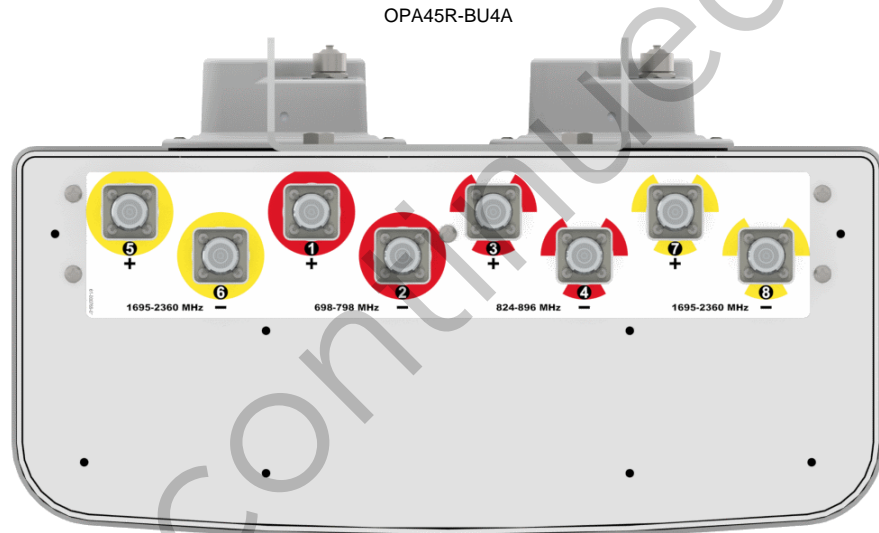

Connection Spacing Diagram

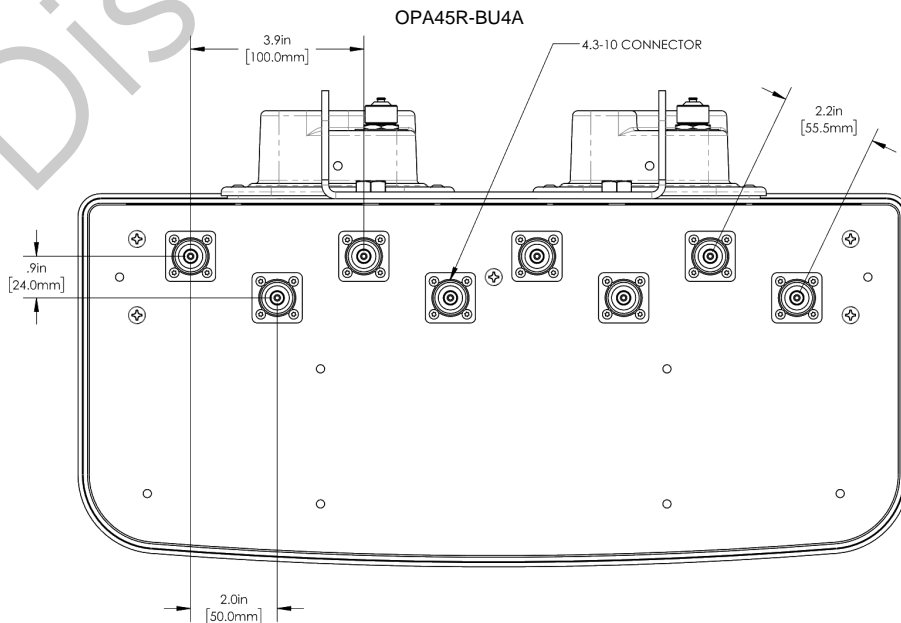

RET to Element Configuration

OPA45R-BU4AA RET to Element Configuration

## Top of antenna Viewed from rear

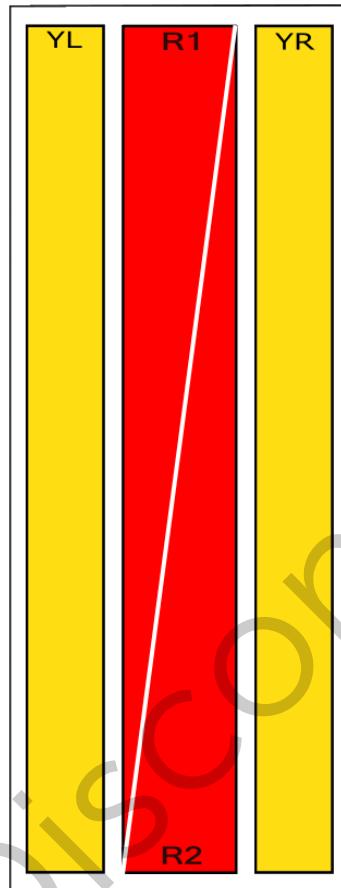

### RET placement as view from rear of antenna

Top of antenna

698-798  
Ports 1, 2  
(R1)



824-896  
Ports 3, 4  
(R2)

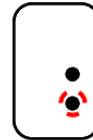

1695-2360  
Ports 5, 6, 7, 8  
(YL & YR)



Array	Ports	Freq (MHz)	Ports controlled by common RET
R1	1, 2	698-798	1, 2
R2	3, 4	824-896	3, 4
YL	5, 6	1695-2360	5, 6, 7, 8
YR	7, 8	1695-2360	



OctoPort Multi-Band Antenna

OPA45R-BU4A

SPECIFICATIONS

Typical Antenna Patterns

For detailed information on additional antenna patterns, contact customer support at support@cciproducts.com

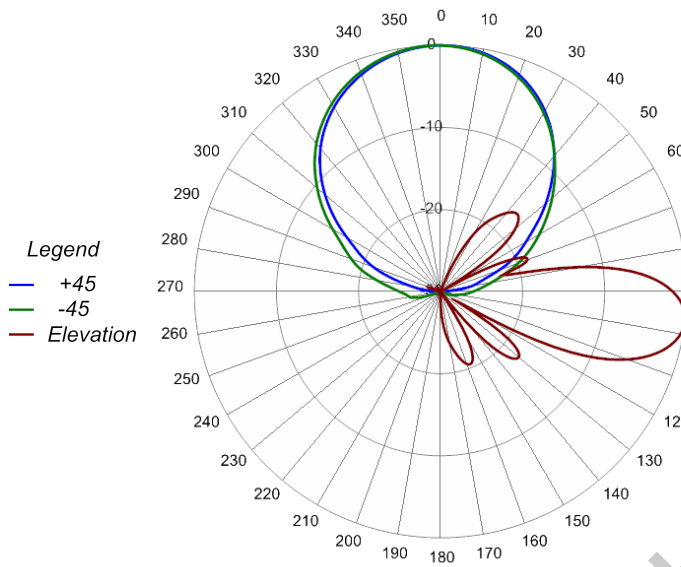

710 MHz Azimuth with Elevation 7°

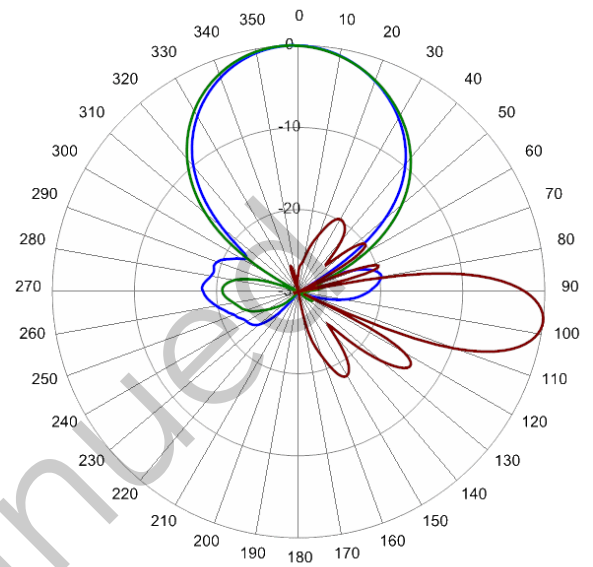

840 MHz Azimuth with Elevation 7°

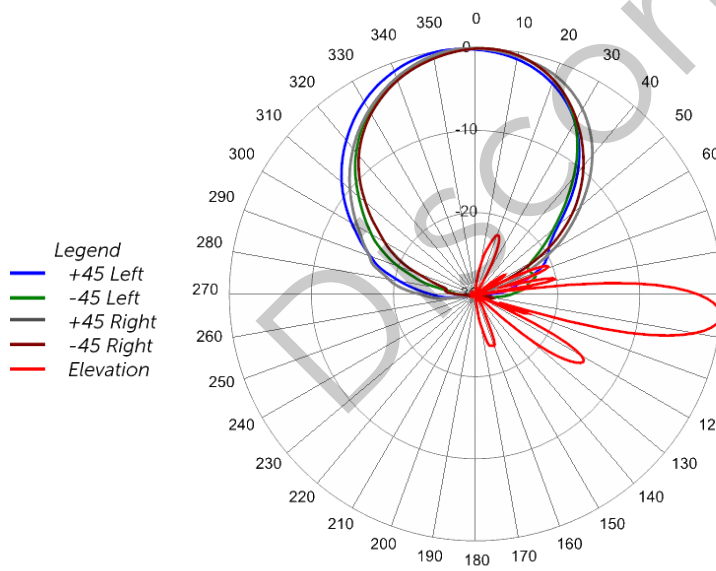

1740 MHz Azimuth with Elevation 5°

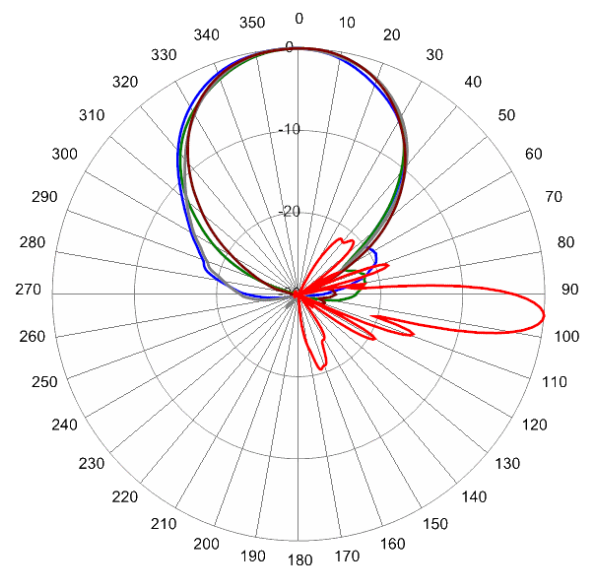

1970 MHz Azimuth with Elevation 5°

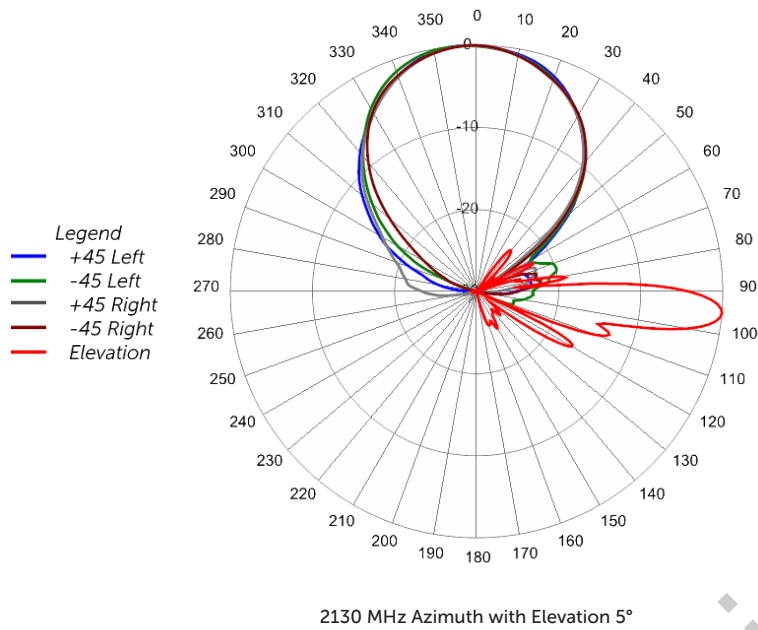

Discontinued



Parts & Accessories

<b>OPA45R-BU4AA-K</b>	Four foot (1.3 m) OctoPort antenna with 45° azimuth beamwidth, 4.3-10 female connectors, 3 factory installed BSA-RET200 RET actuators (Type 1 external) and MBK-02 mounting bracket
<b>OPA45R-BU4AB-K</b>	(Future Development) Four foot (1.8 m) OctoPort antenna with 45° azimuth beamwidth, 4.3-10 female connectors, 3 factory installed BSA-RET400 RET actuators (Type 17 internal) and MBK-02 mounting bracket
<b>MBK-02</b>	Mounting bracket kit (top and bottom) with 0° to 10° mechanical tilt adjustment
<b>BSA-RET200</b>	Remote electrical tilt actuator
<b>HPA-CBK-AG-RRU</b>	OctoPort antenna with 3 RET to RRU AISG cable kit
<b>HPA-CBK-RA-AG-RRU</b>	OctoPort antenna with 3 RET to RRU AISG right angle cable kit

Discontinued



Mounting Bracket Kit

MBK-02

Mechanical

<b>Weight</b>	9.8 lbs (4.4 kg)
<b>Hinge Pitch</b>	31.5 in (800 mm)
<b>Mounting Pole Dimension</b>	2 to 5 in (5 to 12 cm)
<b>Fastener Size</b>	M10
<b>Installation Torque</b>	15 ft-lbs (20 N·m)
<b>Mechanical Tilt Adjustment</b>	0° - 10°

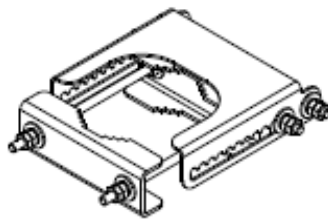

MBK-02 Top Adjustable Bracket

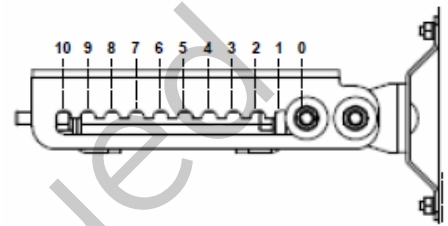

MBK-02 Top Adjustable Bracket Side View

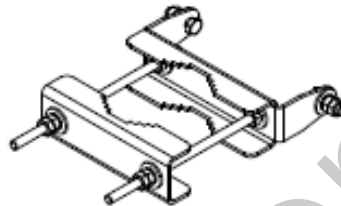

MBK-02 Bottom Fixed Bracket

Discontinued



### Remote Electrical Tilt Actuator (RET)

BSA-RET200

#### General Specifications

Part Number	BSA-RET200
Protocols	AISG 2.0
RET Type	Type 1
Adjustment Cycles	>10,000 cycles
Tilt Accuracy	±0.1°
Temperature Range	-40° C to 70° C

#### Electrical

Data Interface Signal	DC
Input Voltage	10-30 Vdc
Current Consumption Tilt	120 mA at $V_{in}=24$
Current Consumption Idle	55 mA at $V_{in}=24$
Hardware Interface	AISG-RS 485 A/B
Input Connector	Male 1 × 8 pin Daisy Chain
Output Connector	Female 1 × 8 pin Daisy Chain

#### Mechanical

Dimensions (LxWxD)	8.0x5.0x2.0 in. (213x135x51 mm)
Housing	ASA/ABS/Aluminum
Weight	1.7 lbs (0.75 kg)

ASA= Acrylic Styrene Acrylonitrile  
ABS=Acrylonitrile Butadiene Styrene

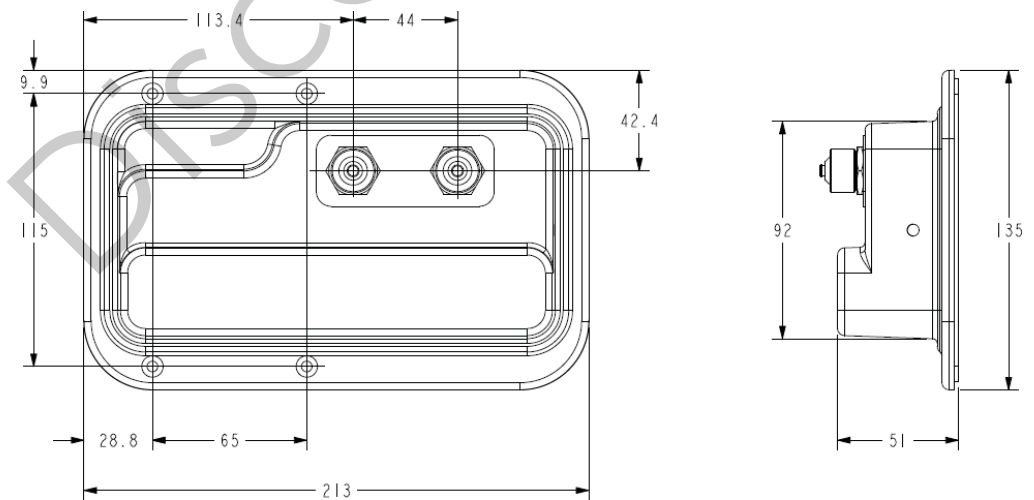



Electrical Specifications

<b>Individual Cable Part Number</b>	AISGC-M-F-18	AISGC-M-F-10FT
<b>Cable style</b>	UL2464	UL2464
<b>Protocol</b>	AISG 1.1 and AISG 2.0	AISG 1.1 and AISG 2.0
<b>Maximum voltage</b>	300 V	300 V
<b>Rated current</b>	5 A at 104° F (40° C)	5 A at 104° F (40° C)

Mechanical Specifications

<b>Individual Cable Part Number</b>	AISGC-M-F-18	AISGC-M-F-10FT
<b>Cables per kit</b>	2	2
<b>Connectors</b>	2 x 8 pin IEC 60130-9 Straight male/straight female	2 x 8 pin IEC 60130-9 Straight male/straight female
<b>Tightening torque</b>	Hand tighten only ≈ 1.84 ft-lbs (2.5 N-m)	Hand tighten only ≈ 1.84 ft-lbs (2.5 N-m)
<b>Construction</b>	Shielded (Tinned Copper Braid)	Shielded (Tinned Copper Braid)
<b>Braid coverage</b>	85%	85%
<b>Jacket Material</b>	Matte Polyurethane (Black)	Matte Polyurethane (Black)
<b>Conductors</b>	1 twisted pair - 24 AWG 3 conductors - 19 AWG AWM style 2464	1 twisted pair - 24 AWG 3 conductors - 19 AWG AWM style 2464
<b>Cable Diameter</b>	0.307 in (7.8 mm)	0.307 in (7.8 mm)
<b>Length</b>	18 - 20 in (457 - 508 mm)	120 in (3048 mm)
<b>Weight</b>	0.27 lbs (0.12 kg)	0.69 lbs (.31 kg)
<b>Minimum bend radius</b>	3.9 in (100 mm)	3.9 in (100 mm)

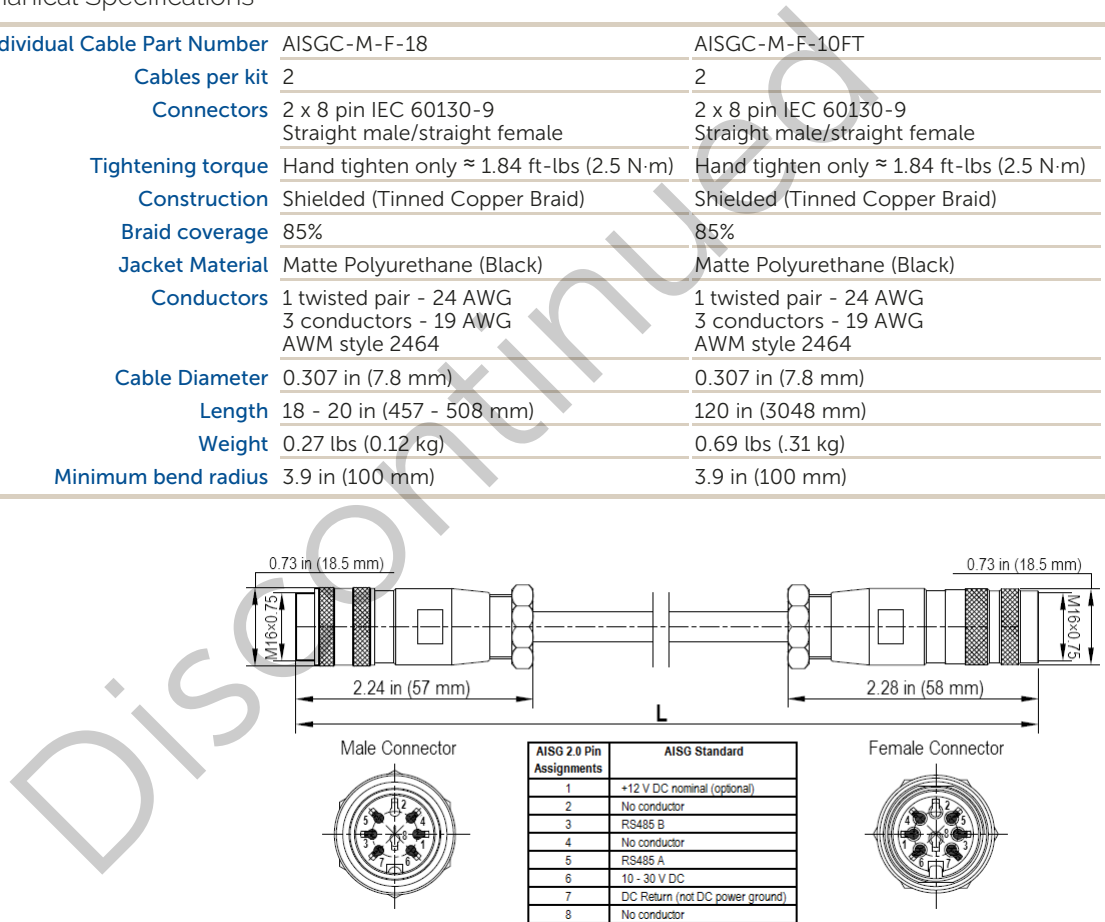

AISG-Male to AISG-Female Jumper Cable

Environmental Specifications

<b>Individual Cable Part Number</b>	AISGC-M-F-18	AISGC-M-F-10FT
<b>Temperature Range</b>	-40° to 80° C	-40° to 80° C
<b>Flammability</b>	UL 1581 VW-1	UL 1581 VW-1
<b>Ingress Protection</b>	IEC 60529:2001, IP67	IEC 60529:2001, IP67

Electrical/Mechanical/Environmental Specifications

	RET to RET Cables	RRU to Antenna Cables
Individual Cable Part Number	AISGC-MRA-FRA-20	AISGC-M-FRA-10FT
Cable style	UL2464	
Protocol	AISG 1.1 and AISG 2.0	
Maximum voltage	300 V	
Rated current	5 A at 104° F (40° C)	
Temperature Range	-40° to 80° C	
Flammability	UL 1581 VW-1	
Ingress Protection	IEC 60529:2001, IP67	
Tightening torque	Hand tighten only ≈ 1.84 ft-lbs (2.5 N·m)	
Construction	Shielded (Tinned Copper Braid)	
Braid coverage	85%	
Jacket Material	Matte Polyurethane (Black)	
Conductors	1 twisted pair - 24 AWG 3 conductors - 19 AWG AWM style 2464	
Cable Diameter	0.307 in (7.8 mm)	
Minimum bend radius	3.9 in (100 mm)	
Connectors	2 x 8 pin IEC 60130-9 Right angle male/right angle female	2 x 8 pin IEC 60130-9 Straight male/right angle female
Length	20 in (508 mm)	120 in (3048 mm)
Weight	0.23 lbs (0.10 kg)	0.77 lbs (0.35 kg)
Cables per kit	2	2

Mechanical Specifications

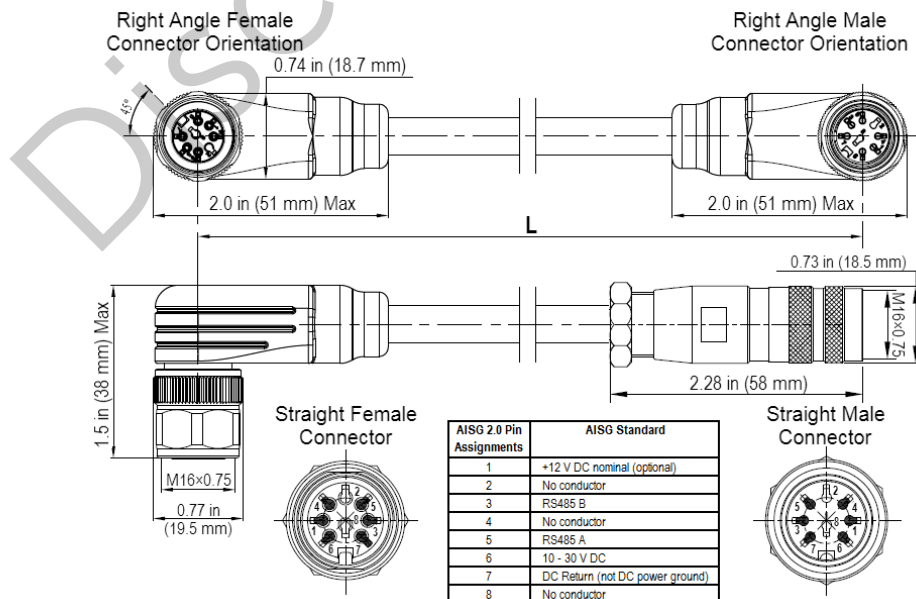

Right Angle to Right Angle and Right Angle to Straight Jumper Cable



STANDARDS & CERTIFICATIONS

OctoPort Multi-Band Antenna

OPA45R-BU4A

Standards & Compliance

<b>Safety</b>	EN 60950-1, UL 60950-1
<b>Emission</b>	EN 55022
<b>Immunity</b>	EN 55024
<b>Environmental</b>	IEC 60068-2-1, IEC 60068-2-2, IEC 60068-2-5, IEC 60068-2-6, IEC-60068-2-11, IEC 60068-2-14, IEC 60068-2-18, IEC 60068-2-27, IEC 60068-2-29, IEC 60068-02-30, IEC 60068-2-52, IEC 60068-2-64, GR-63-CORE 4.3.1, EN 60529, IP 24

Certifications

Antenna Interface Standards Group (AISG), Federal Communication Commission (FCC) Part 15 Class B, CE, CSA US, ISO 9001

